

Letter to the Editor

A very low attenuation fiber-optical sensor switch (LAFOSS)

H. Hecht^{*}, M. Kölling

Department of Geosciences, University of Bremen, P.O. Box 330440, 28334 Bremen, Germany

Received 15 June 2001; received in revised form 24 August 2001; accepted 27 August 2001

Abstract

For multiple sensor oxygen measurements in the gas phase of experimental columns filled with pyrite bearing sediments an automated switch was constructed which allows to connect one MICROX 1 optical oxygen measurement system to 12 optodes. Since our switch simulates the manual connection of the optode ST connector to the ST–ST coupler at the instrument front panel the attenuation of the signals introduced by the sensor switch is as low as 0.2 dB compared to the single sensor system. First measurements using this low attenuation fiber-optical sensor switch (LAFOSS) for the determination of oxygen diffusion in the vadose zone of sediments are presented.

© 2001 Elsevier Science B.V. All rights reserved.

Keywords: Array; Attenuation; Optode; Oxygen; Vadose zone; Diffusion

1. Introduction

Fiber-optical measuring systems are opening up a number of new perspectives in measuring technology. The technical structure of single fiber-optical measuring systems with an optical module that is consisting of both the light source and the detector makes it difficult to switch between several sensors automatically without attenuation of the signal.

Attenuation at every coupler has a dual effect since both, the excitation light and the low-intensity fluorescent response are attenuated. A low signal attenuation is preferable since it allows accurate measurements at short measuring cycles due to a good signal-to-noise ratio (SNR). Increasing the intensity of the excitation light also enhances the SNR, but at the cost of a reduced sensor chemistry life cycle. Commercially, available optical fiber switches are usually optimized for high switching speed in the range of milliseconds. These switches exhibit a magnitude of signal attenuation that is disadvantageous for the use with fiber-optical sensors. We constructed a simple, inexpensive, but slow switch (prototype switching time 20 s) which shows extremely low attenuation when directly connected to the instruments analyzer module.

2. Materials and methods

The optical oxygen sensors [1] are constructed from standard 100/140 μm multimode graded index silica fiber cables with ST connectors (Radiall, #F796276021, Roedermark, Germany). Inside the original instrument (MICROX 1, PreSens [2]), a fiber cable of the same type connects the optical I/O module to a self-centering ST–ST coupler (Radiall, #F709722000) in the front panel. Similar ST–ST front panel couplers have been modified for the use in LAFOSS to allow automated operation by removing the bayonet notches on one side. The front panel end of the fiber cable is used in LAFOSS for switching operation (see Fig. 1).

The switch is driven by two stepper motors and controlled via a microcontroller, BASIC STAMP II [3]. The BASIC STAMP microcontroller is programmed via a serial interface connected to a PC using a BASIC compiler for Win95 provided by PARALLAX [3] (Rocklin, CA, USA).

3. LAFOSS principle

Connecting two optical fibers manually using ST connectors and ST–ST front panel couplers results in very low signal attenuation since the spring force of the ST connector bayonet ring and a centering spring inside the ST–ST coupler provide a very precise coupling. The basic idea behind LAFOSS was to connect a number of sensors to standard ST–ST couplers in a front panel and to automate the variable connection of multiple sensor cables to one

^{*} Corresponding author. Tel.: +49-421-218-3928;

fax: +49-421-218-4321.

E-mail address: hhecht@uni-bremen.de (H. Hecht).

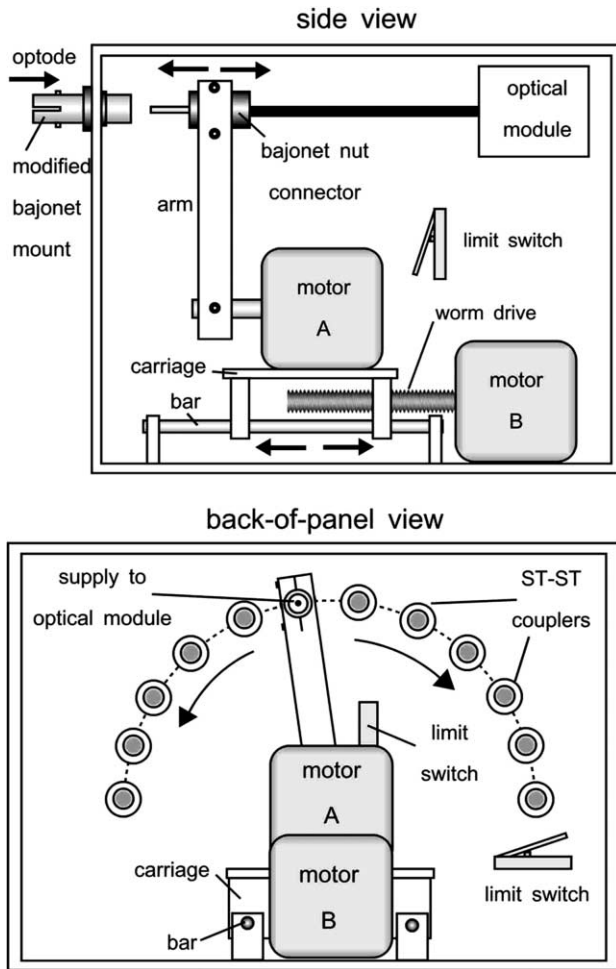

Fig. 1. General structure of the very low attenuation fiber-optical sensor switch (LAFOSS). Above: side view; below: back-of-panel view.

electro-optical setup of the measuring system. Since in our application switching times of several seconds are no problem, we were able of constructing a cheap and simple automation unit for this purpose.

In the prototype version of LAFOSS a simple mechanical setup with two stepping motors was applied to construct an optical fiber switch with 12 channels. Fig. 1 illustrates the mechanical details of the LAFOSS. The centerpieces of the switch are two stepping motors and a carriage. Stepper motor A is moving an arm directly connected to the motor's axis on a circular trajectory. Stepper motor A itself is mounted to a carriage that may be moved back and forth by a worm drive operated by stepper motor B. In the prototype switch, 12 modified ST-ST couplers are positioned on a half circle at the switch front panel. The ST connector fixed to the arm may be positioned in front of each coupler by motor A. The connector may now be plugged in and out by moving motor B. We used a worm drive for this movement, since sufficient force is needed to insert the connector into the self-centering ST coupler. A switching operation lasts about 20 s. The system is controlled by a microcontroller which allows both, stand alone operation and online computer control via a serial interface (RS232 connection).

4. Measurements

4.1. Determination of attenuation

The blue-green light of a LED (505 nm) driven at a constant current of 20 mA is coupled into a 100/140 μm graded index fiber. The light is transmitted through two 100/140 μm fiber cables connected via a ST-ST coupler to a photodiode detector setup (Fig. 2, top). The resulting light signal is recorded as a current that is directly proportional to the detected light power. Signal noise is in the range of pA and may be neglected.

Before and after the measurements with the switch, reference measurements were carried out with the setup as described above. Taking these signals as non-attenuated signals, the extra attenuation introduced by the fiber switch

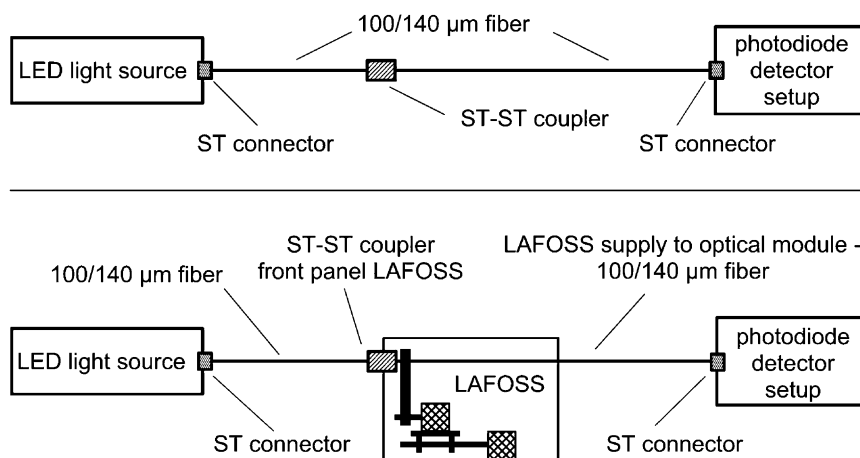

Fig. 2. Experimental setup for attenuation measurements. Top: setup for reference measurement without LAFOSS; bottom: setup with LAFOSS.

Table 1
Attenuation introduced by fiber switch compared to direct coupling

Repeat no.	Non-attenuated signal (nA)			Signal (nA) with switch in position number					
	Before	After	Mean	1	2	3	4	5	6
1	155.5	154.8		149.0	148.7	149.3	149.5	149.8	150.7
2	155.3	155.1		149.1	148.6	149.5	149.7	150.1	150.4
3	155.4	155.4		148.8	148.9	149.6	149.7	150.1	150.3
Mean	155.4	155.1	155.3	149.0	148.7	149.5	149.6	150.0	150.5
Attenuation (dB)				0.18	0.19	0.16	0.16	0.15	0.14

may be quantified. For this purpose, one fiber cable and the ST–ST coupler of the setup were replaced by the switch (Fig. 2, bottom). Table 1 shows the results of three repeats and the resulting attenuation for six different channels of the switch. The measurements show, that the automatic switch introduces an extra attenuation below 0.2 dB.

4.2. Application of the LAFOSS

Using the optical fiber switch in a diffusion experiment, the change in ground air oxygen concentration was detected with a MICROX 1 instrument and seven sensors that permanently remained in the experimental setup in order to avoid disturbance by sensor introduction. The column consists of a perspex tube with a diameter of 10 cm and a length of 70 cm. It is filled with silty fine to medium grained sand (dry bulk density, 1.35 g/cm³; porosity, 0.49; water content, 0.2). The column was initially filled with nitrogen from below. Upon start of the experiment the top of the column is opened allowing free diffusive equilibration with atmospheric oxygen. At different depths, oxygen optodes were permanently installed in luer-lock sampling ports. With these optodes, the change in the oxygen depth-distribution was recorded (Fig. 3). Filled circles reflect measurements, contours show oxygen saturation where 100% is equivalent to ambient oxygen partial pressure, $p_{O_2} = 0.21$.

The achieved data can be used to determine soil-physical parameters (e.g. tortuosity) of the soil [4]. They are basic data for quantifying and predicting transport processes within the liquid and gaseous phase of porous media.

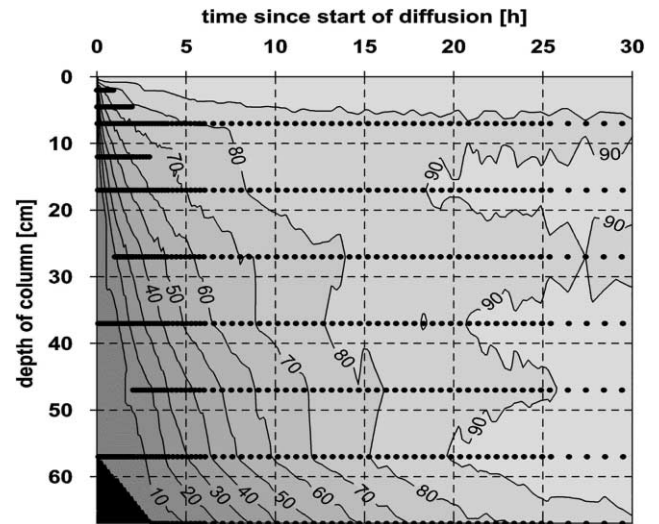

Fig. 3. Diffusion of ambient oxygen into a soil column where ground air has been replaced by nitrogen prior to experiment. Contours show oxygen saturation (100% is equivalent to $p_{O_2} = 0.21$). Filled circles show measurements. Seven optodes were used simultaneously. Switching between sensors was conducted with array described above (LAFOSS).

5. Discussion

The switch presented here shows a signal attenuation below 0.2 dB. Commercially, available switches for multi-mode fibers are evidently featured with higher attenuations (viz. Table 2).

Commercially available fiber switches are optimized for high wavelengths. Using these switches for the transmission

Table 2
Attenuation (insertion loss) of several commercially available fiber switches

Company	Product	n	Wavelength (nm)	Insertion loss (dB)	Source
Dicon Fiberoptics	1x8 Prism switch	8	1550	2.5 max.	www.diconfiberoptics.com
Dicon Fiberoptics	Simplex 1xn	50	1550	0.6 typ., 1.2 max.	www.diconfiberoptics.com
EXFO Electro-Optical Engineering	IQ-9112	12	850	0.5 typ., 1.0 max.	www.exfo.com
Piezosystem Jena	F-SM 11	2	n/a	0.8 typ., 1.5 max.	www.piezोजना.de
Piezosystem Jena	F-SM 16	6	n/a	2.0 typ., 2.5 max.	www.piezोजना.de
Piezosystem Jena	F-SM 19	9	n/a	2.0 typ., 2.5 max.	www.piezोजना.de
Sercalo Microtechnology	SW1x4-9N-12-16	4	1240–1600	1.0 typ., 1.5 max.	www.sercalo.com
ILX Lightwave	FOS-79710	4	1290–1650	1.2 typ., 1.7 max.	www.ilxlightwave.com

of blue–green light results in higher signal attenuation than specified. Comparative measurements with a formerly commercially available switch (Dicon, Richmond, USA) resulted in an average signal attenuation of 1.6 dB at 505 nm [5]. A comparable switch (Piezo Jena, Germany) is integrated into the multichannel measuring instrument Microx 8 (PreSens, Regensburg, Germany) showing clearly higher signal attenuation than a single-channel measuring instrument extended by LAFOSS.

In most of the examined systems, the temporal changes in oxygen concentrations are small (significant changes within the range of minutes to days). The relatively long switching cycles between the individual sensors, are therefore, no limitation for the investigation of transport processes. Due to the small concentration changes with time, a high measuring accuracy is of great importance. LAFOSS enables the automated measurement over long periods with high measuring accuracy. By optimizing both operating paths and mechanical components the switching cycle may easily be reduced to 5 s if needed.

6. Conclusion

When extremely low signal attenuation is more important than short switching cycles, the LAFOSS may be used to turn a single sensor optode measuring system into a multisensor array. It is featured with less noise than other arrays resulting in an enhanced measuring accuracy in conjunction with an enhanced life cycle of the fluorescence dye.

Acknowledgements

The LAFOSS was developed within a project granted by the Deutsche Forschungsgemeinschaft (DFG-Ko-1656/2-1). This paper represents publication no. 166 of the Priority Program 546 “geochemical processes with long-term effects in anthropogenically affected seepage water and

groundwater”. Thanks for inexhaustible help to G. Holst (MPI for Marine Microbiology, Bremen).

References

- [1] I. Klimant, G. Holst, M. Köhl, Oxygen micro-optodes and their application in aquatic environment, *Proc. SPIE* 2508 (45) (1995) 375–386.
- [2] URL: <http://www.presens.de/microx1.pdf>.
- [3] URL: <http://www.parallaxinc.com>.
- [4] H. Hecht, Optodenmessung zur Bestimmung diffusiver Sauerstoffnachlieferung bei der Pyritverwitterung, diploma theses, unpublished, University of Bremen, Department of Geosciences, 1998, 90 pp.
- [5] C. Stehning, Theoriegrundlagen, Aufbau und Vermessung eines volloptischen Lichtwellenleiter-Multiplexers, student research project, unpublished, University of Bremen Department of Physics and Electrical Engineering and Max-Planck-Institute for Marine Microbiology, Bremen, 2001, 93 pp.

Biographies

Henrik Hecht born in 1972, studied geology at the University of Bremen, Germany and received the diploma in 1998 with a final work about use of fiber-optical sensors for the determination of diffusive oxygen transport in pyrite bearing sediments. Since 1998, he has been working on his PhD in the geochemistry and hydrogeology group of Professor H.D. Schulz at the department of geosciences, University of Bremen, Germany about long-term stable fiber-optical oxygen sensors for monitoring of pyrite weathering processes.

Martin Kölling born in 1959, studied geology at the Christian-Albrechts-University in Kiel, Germany where he received the diploma in 1986 with a final work about the determination of redox potentials in natural waters. From 1986 to 1990, he completed his PhD in the hydrogeology and marine geochemistry group of Professor H.D. Schulz at the department of geosciences, University of Bremen, Germany about the application of geochemical models and the formation of acid mine drainage. In 1990, he became lab manager in the same group and continued his work on acid mine drainage and on redox systems. In 1996, he started a project in cooperation with the Microsensor Research Group of the Max-Planck-Institute for Marine Microbiology on the application of fiber-optical techniques to ground- and seepage water systems affected by acid mine drainage formation. His scientific interests are in the conversion of fiber-optical sensor techniques originally developed for the microscale to cheap and long-term stable sensing systems for monitoring purposes.