

A simple plastic fiber based optode array for the in-situ measurement of ground air oxygen concentrations

Martin Kölling*^a, Henrik Hecht^a and Gerhard Holst **^b

^a Dept. of Geosciences, Univ. Bremen, Germany, ^b MPI f. Marine Microbiology, Bremen, Germany

ABSTRACT

A fiberoptical optode array for the in-situ measurement of ground air oxygen concentrations has been used in both, lab and field experiments to monitor subsurface oxygen consumption in a lignite mine tailing affected by acid mine drainage formation. The single sensors are constructed from plastic fibers (core diameter 1 mm) with an oxygen sensitive fluorescent dye film attached to the fiber tip. Measurements were performed with a commercially available oxygen measuring instrument (MICROX 1, PreSens, Regensburg, Germany) which had been modified for the use with 1 mm plastic fibers. The instrument evaluates the oxygen dependent change of the luminescence lifetime of an oxygen indicator using a phase modulation technique. First measurements show a strong oxygen consumption by pyrite oxidation indicated by a ground air oxygen concentration gradient pointing to a depth of approximately 6 m. The measurement of the pyrite depth distribution of the material confirms the assumption that the 40 year old tailing has been depyritized down to a depth of 6 m and that pyrite oxidation and acid mine drainage formation are still going on. Investigations will proceed in order to assess long-term sensor stability under strongly acid conditions.

Keywords: Optode, fiber optical sensor, luminescence life time, pyrite weathering, oxygen diffusion, coupling

1. INTRODUCTION

In the last years, fiberoptical chemical microsensors, microoptodes, have been introduced for the measurement of oxygen⁵⁻⁷, temperature^{4,7} and other parameters⁹ mainly for microbiological or medical applications either as a replacement or an improvement for electrochemical microsensors, microelectrodes. Especially in microbial systems with steep gradients in oxygen concentrations, microsensors may be used to measure concentrations at a spatial resolution in the range of micrometer^{1-4, 5-9, 15}. In our application we were interested in determining gradients in oxygen concentrations in pyrite bearing tailings of open-cast lignite mines which represent strongly oxygen consuming systems, yet at a much larger scale of decimeters to meters. In column experiments with original material from the tailings, the pyrite oxidation process was investigated. One major parameter indicating ongoing oxidation is the gradient in ground air oxygen concentration. Since the oxygen recharge in such water-unsaturated soil systems is mainly diffusive, ground air sampling was applicable only in large-scale experiments since otherwise the effect of sampling on the diffusion process was not neglectable. We decided to use oxygen optodes to allow a detection of oxygen concentrations at several depths without any disturbance even in small column experiments. The straight forward approach was to use a commercially available system (PreSens, MICROX 1) with a silica fiber based oxygen microoptode which is introduced into the experimental column through sampling ports at different depths. In order to avoid damage of the fragile microoptodes, one sensor was permanently installed at each depth. This required a lot of reasonably expensive microoptodes which limited the range of investigations. Since some of the advantages of the microoptodes such as a fast response time, in the range of seconds, and a small sensor tip size, around 30 μm , did not account for our application, we decided to optimize both the sensors and the measuring system in order to get inexpensive and rugged sensors which can be easily prepared.

* koelling@uni-bremen.de phone: +49-421-218-3928, fax: +49-421-218-4321, Department of Geosciences, University of Bremen, Klagenfurter Str., D-28359 Bremen, Germany, ** gholst@mpi-bremen.de, phone: +49-421-2028-834 fax: +49-421-2028-690, Microsensor Group, Max Planck Institute for Marine Microbiology, Celsiusstr. 1, D-28359 Bremen, Germany

2. MATERIAL AND METHODS

2.1 Measuring instruments

The applied optical oxygen measuring instruments, utilize the well known dynamic or collisional quenching of luminescence as basic phenomenon for detection. Both, the luminescence lifetime and the luminescence intensity of indicator molecules like certain ruthenium compounds and porphyrines are oxygen concentration dependant. Since the intensity of the luminescence may change when the optical fiber is moved or bended, while the luminescence lifetime as parameter is less susceptible to noise influences on the optical path, the luminescence lifetime signal rather than the luminescence intensity is analysed in the PreSens instruments.

2.2 Optical coupling

In many optode measuring systems as used in this project, the optode is a single fiber which serves for both guiding the excitation light to the sensor tip and returning the luminescence response to the detector. In all measuring systems excitation light is generated by a modulated high-intensity LED (for oxygen measurements typically at $\lambda_p=470\text{nm}$). Referencing of the system is obtained by alternately measuring the luminescence excited by the blue LED and red light emitted by a reference LED. To solve the general task of using the same light path for both directions, to and from the sensor, there exist three possible coupling methods, that are shown in figure 1.

The traditional way is a beamsplitter setup (Fig. 1 [A]) in which a semi-reflective mirror is used to couple 50% of the excitation light (Fig. 1 ex) into the fiber. Fifty percent of the signal light reaches the detector via the same mirror (Fig. 1 det). The transmission can be improved if a wavelength selective (dichroic) mirror can be used (for luminescence measurements with a large Stoke's shift). The setup is simple by its structure and can achieve in case of the dichroic mirror high signals. But a very good blocking efficiency of the optical filters is necessary because large amounts of excitation light may reach the detector by direct reflections within the setup. Additional background signals may arise because of the unwanted luminescence of materials that are currently used to make fiberoptical plugs and their fixation glues. Furthermore, each part of the beamsplitter setup needs a relatively high level of adjustment (see table 1).

The second possible method are fiber couplers (Fig. 1 [B]), e.g. 2x2 fusion couplers or grinded couplers or as currently released, GRIN lens couplers (Fig. 2 fcop). These are standard products of the telecommunications industry and if they are once supplied with standard optical fiber plugs, their assembly is simple, with a low level of adjustment. Like the beamsplitter they have 50% attenuation in both directions. Even here luminescence might occur because of the glue used to fix the treated part of the used fibers mechanically. Nevertheless, the optical filters in such a system do not need such a high quality because the excitation light is only guided indirectly to the detector by reflections from the coupler and the fiber endfaces (see table 1).

Table 1: Comparison of optical coupling methods for microoptodes.

coupling	pro	con
beam splitter, dichroic beam splitter	<ul style="list-style-type: none"> • simple setup • with dichroic mirror higher signal transmission 	<ul style="list-style-type: none"> • good blocking efficiency of optical filters is mandatory • high level of adjustment • high background "noise"
fiber coupler	<ul style="list-style-type: none"> • simple adjustment with standard equipment 	<ul style="list-style-type: none"> • high signal loss (50%) • fragile setup
external in- or out-coupling	<ul style="list-style-type: none"> • smallest sensor tip (< 1 μm possible) 	<ul style="list-style-type: none"> • restricted to fixed setup • no flexible application of microoptode

The last method is the external in or out-coupling of light (Fig. 1 [C]). In this method the fiber of the microoptode is used for one way of light only, that means either the excitation light is launched into the fiber, which is shown in figure 1, and the light signal is collected externally^{10,11}, or the fiber tip is illuminated externally and the light signal is guided through the fiber to the detector. This method allows the use of fiber tips smaller than 1 μm in diameter that enable

measurements even in single cells. For flexible applications in biofilms or sediments, however, this method is not useful, because it is extremely confined to a special fixed setup (table 1).

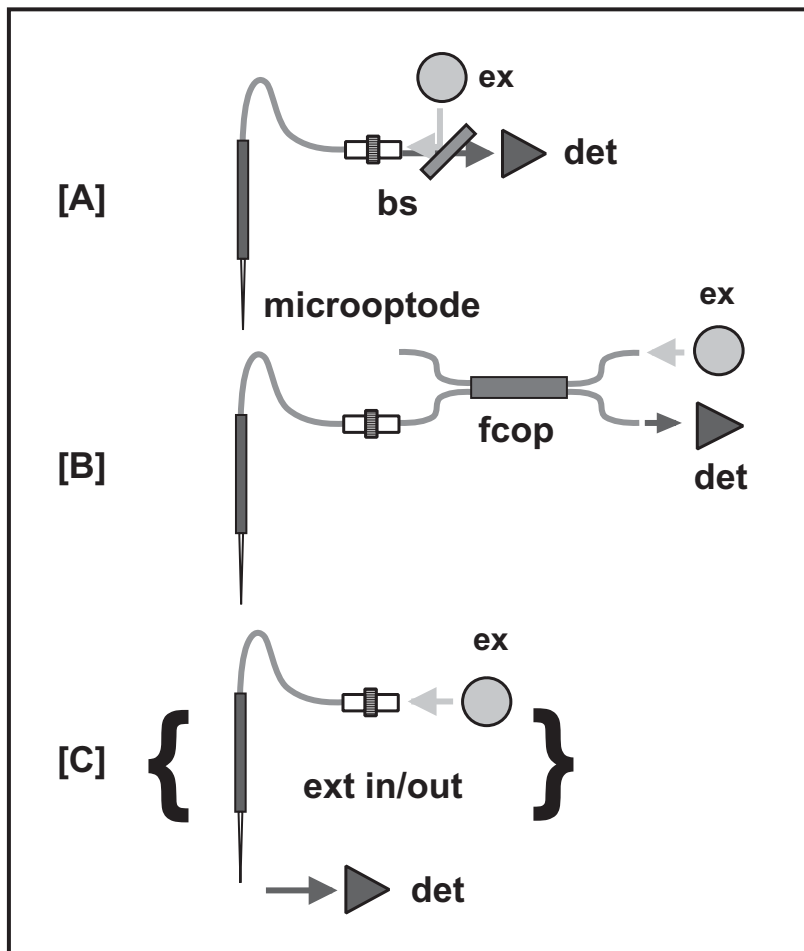

Figure 1: Possible methods of optical coupling for microoptodes (schematic drawing): [A] Classical beamsplitter (bs) setup - the position for in and out coupling of excitation and emission light can be exchanged, the performance can be improved if a wavelength selective mirror can be used. [B] Fiber coupler (fcop) setup - the 2x2 fiber coupler is a standard device in telecommunications technology. [C] External in or out coupling (ext in/out) setup - here the lightguiding property of the microsensor is only used for one direction, either excitation or emission, and is therefore restricted to the whole experimental setup.

2.2.1 Optical coupling of MICROX 1

The PreSens MICROX 1 instrument uses a 2x2 100/140µm quartz fiber coupler (Gould, USA) to separate the excitation light from the luminescence signal. The four ends of the coupler are connected to the blue LED excitation light source and the detector on one side and to the microoptode connector and the reference LED on the other side. Inside the commercially available instrument, a standard photomultiplier (Hamamatsu Photonics, Germany) is used for the detection of the luminescence signal.

Because of the weak light signal, which usually was in the range of 10-50 pW for the first microoptodes, a photomultiplier tube (PMT) had to be used. The coupler was chosen because of its availability as standard device, the simple adjustment and its low internal background fluorescence signal. The second left branch of the coupler was used

to couple in light of a red LED (Fig. 2 LED_{ref}) alternately to the excitation light (Fig. 2 LED_{sig}) to obtain a reference signal that is necessary for evaluating the zero phase angle of the system for the phase modulation technique.

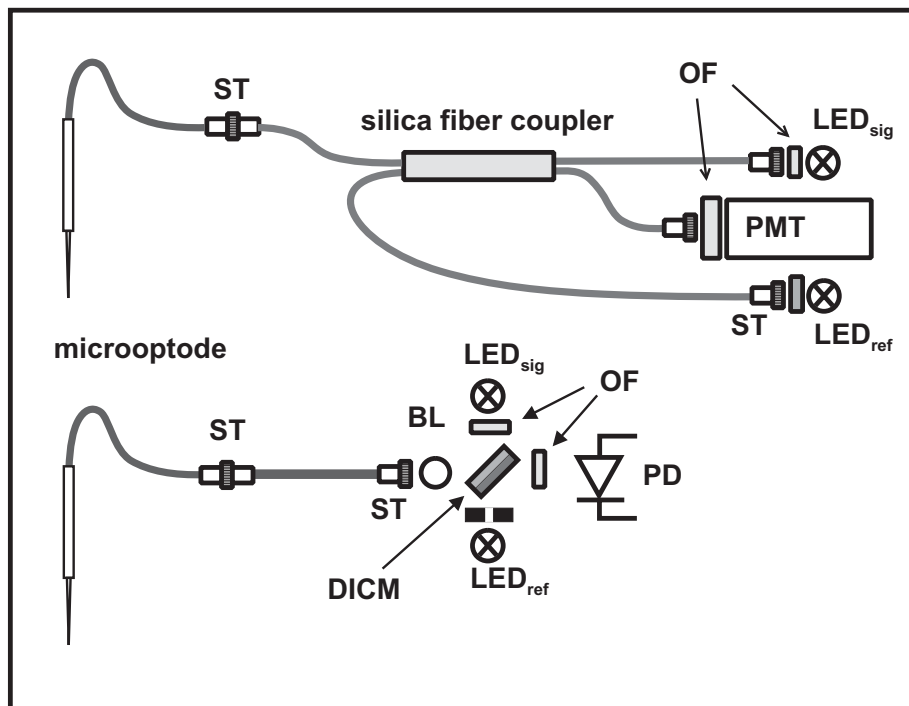

Figure 2: Optical setups of the measuring systems MICROX 1 & 2 prototype (schematic drawing). **Above:** MICROX 1- The excitation light (light emitting diode, LED_{sig}) is launched via an excitation filter (OF) and a standard fiber connector (ST) into one branch of a fiber coupler (silica fiber coupler). The microoptode is connected to one branch of the coupler on the left side via standard fiber connectors (ST). The emitted light of the sensor tip is guided back and reaches via the second branch on the right side, via fiber connector (ST) and emission filter (OF) the photodetector (photomultiplier tube, PMT). The reference light source (a red light emitting diode, LED_{ref}) uses the second branch on the left side to couple in its light to the signal path.. **Below:** MICROX 2 prototype: The excitation light (light emitting diode, LED_{sig}) is launched via an excitation filter (OF), a dichroic mirror (DICM), a ball lens (BL) and a standard fiber connector (ST) into an adapter fiber which is connected to the microoptode. If a 1 mm minioptode with SMA connector as described below is used, only this adapter fiber and the frontplate connector have to be replaced. The emitted light of the sensor tip is guided back and returns by the same path to the dichroic mirror where it is transmitted. Then the light reaches via an emission filter the photodetector (photodiode, PD). The reference light (a red light emitting diode, LED_{ref}) passes a small aperture and is reflected on the back surface of the dichroic mirror onto the detector.

2.2.2 Optical coupling of MICROX 2 prototype

While the light output of the oxygen and temperature microoptodes was further improved (range of 50-200 pW) since the release of the first commercially available sensors and the corresponding instrument, an optimized optical setup based on a dichroic mirror (Fig.2 DICM) was developed that reflects the blue excitation light (Fig. 2 LED_{sig}) and transmits the red emission light. A ball lens is used to couple the light into and out of the fiber efficiently, while the optical filters were carefully selected to optimize the blocking efficiency. In this type of setup there might occur severe sources of background signals that were not expected. Table 2 shows results of measurements with this optical setup that were measured with non modulated light and an excitation LED current of 20 mA.

The situation „empty“ deliver the background signal of 8 pA due to reflections and insufficient blocking within the setup. If just a standard fiber plug with ceramics as material of the ferrule without a fiber is used, there appear two more components in the background signal of 51 pA. More reflected excitation light from the front face that is insufficiently blocked and additional luminescence from the whiteners in the ceramics reach the detector. If subsequently the same

type of plug with inserted and fixed fiber is connected, the background signal rises to 460 pA due to the epoxy, that is used for fixation of the fiber in the plug.

Table 2: Additional luminescence in the dichroic beamsplitter setup – MICROX 2 prototype.

connected to	measured photocurrent [pA]	signal
empty	8	background of the optical setup
fiber plug (ceramics ferrule)	51	luminescence of white ceramics
fiber plug + fiber (ceramics ferrule)	460	luminescence of white ceramics + fiber fixation epoxy
fiber plug + fiber + microoptode (ceramics ferrule)	1870	large signal with large background
fiber plug + fiber (steel ferrule, crimped fiber)	22	background signal of insufficient blocking of excitation light
fiber plug + fiber + microoptode (steel ferrule, crimped fiber)	1080	medium signal with low background

Finally, if a microoptode is connected, the signal amounts to an overall value of 1870 pA, which is a large signal on 25% background. To improve that ratio we used another material for the ferrule and another way of fiber fixation. We found a fairly cheap way of fiber connectors, the so called crimp-and-cleave connection (Radiall, Germany). These fiber plugs have steel ferrules and the fiber is broken not polished and hold by plastic and a metal tube that is crimped onto the fiber. With such a plug and inserted fiber, the background due to increased excitation light reflection on the surfaces was found to be 22 pA. Because of the less defined position of the fiber and the weaker quality of the surface of the broken fiber, there is a smaller coupling efficiency of these connections which can be seen in the lower overall signal of 1080 pA if the same microoptode is connected at the other end of this adapter cable (Fig. 2). But now the background of 2% is more favorable and is smaller than the electronic background. With this setup it was possible to realize for the first time a MICROX system with a cheap and simple photodiode detector (Fig. 2 PD) (Hamamatsu Photonics, Germany).

For the experiments described below we used a PreSens MICROX 2 prototype which was modified for the use with 1mm plastic optical fibers (POF). The decoupling of excitation and luminescence light was obtained by a dichroic mirror setup. The light from a high-intensity blue LED passes a blue interference filter. It is reflected by a dichroic mirror at an angle of 45° via a 5 mm spherical lens into the 1mm optode fiber. The returned red luminescence light from the sensor tip passes the dichroic mirror at an angle of 45°. It is detected by a photodiode after passing a red film filter to eliminate blue scatter light. Referencing is obtained by light from a red LED. Although the dichroic mirror is transparent for red light at an angle of 45° the residual reflection is sufficient to generate a stable and large reference signal.

2.2.3 Optical coupling in FIBOX

The new PreSens instrument (PreSens FIBOX) is designed for the use with 2 mm POF minioptodes. In this instrument, the low signal transmission of a standard 2x2 coupler is avoided by two measures. The reference LED signal fiber is directly coupled to the detector photodiode. Secondly the coupling and decoupling of the excitation light and the luminescence signal is solved with a custom-made 2x1 coupler integrated into the frontplate SMA connector for the optode thus reducing the optional background fluorescence signals. of use of a standard 2x2 couple. The temperature correction of signals is achieved by simultaneous measurement with a standard Pt 100 sensor.

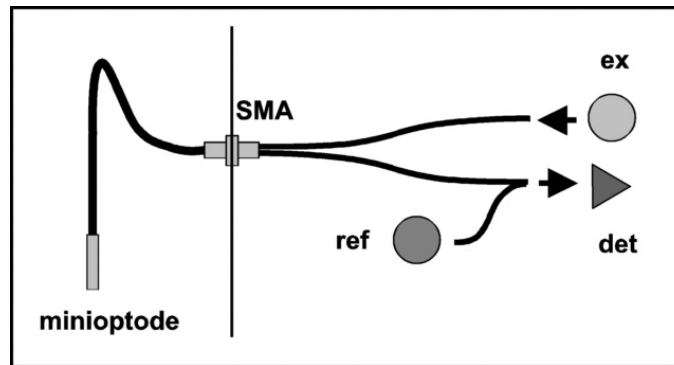

Figure 3: Optical coupling inside FIBOX (schematic drawing): A custom-made 2x1 coupler is integrated into the SMA frontplate connector for the optode. The reference LED light is directly coupled to the detector without attenuation of the luminescence signal.

2.3 POF Sensors

The new sensors for our application are based on butted end 1 mm plastic optical fibers (POF). We used 1 mm POF with a 2.2 mm jacket. For the connection to the instrument a reusable all metal SMA connector (Fischer Elektronik, Germany, LSSM08P) was clamped onto the fiber avoiding extra fluorescence by fixation glue. The sensor tip consists of a punched out sensor spot (diameter 1 mm) from a sensing foil made of a transparent support foil (Mylar, DuPont, USA, thickness = 125 μm) coated with a Ruthenium complex dye immobilised in an organically modified sol-gel. The spot was fixed by a piece of standard plumber PTFE tape and protected by a 500 μm PTFE film wafer. Both, the sensor spot and the protective layers were fixed to the polished tip of the POF by heat shrink tubing. These prototype sensors were used for the measurements described below. Further on they were improved, since the sol-gel matrix does not adhere too well to the carrier film. Therefore the protective layers (PTFE tape, PTFE film) as well serve to keep the sensing layer in place. A well protected version of this sensor is type I, which is built into a steel needle with an aperture at the side. Yet, the response time of the type I sensor is in the range of 30 minutes.

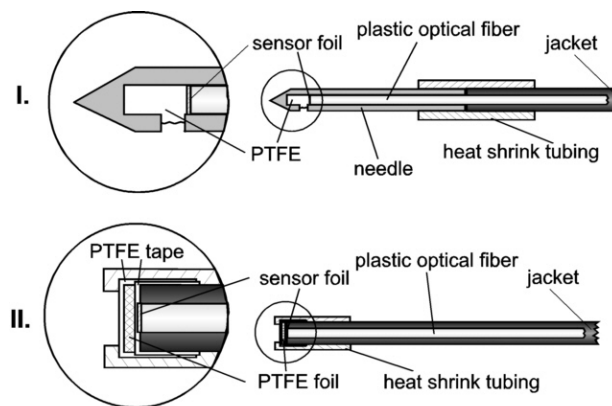

Figure 4: Two types of oxygen minioptodes based on 1mm POF. **I.** slow but rugged sensor with steel needle casing **II.** simple sensor manufactured from polished unstripped fiber with a sensor film spot fixed by standard PTFE tape and heat shrink tubing (Hecht & Kölling¹²).

The type II minioptodes were used in different column experiments and for permanent installation in strongly acidic environments, while the type I sensor with the steel needle casing was used when oxygen measurements were performed by inserting the sensor into soil or sandy sediments. Additionally, temperature sensors were constructed, from sensor foils, where the same ruthenium indicator is immobilized in a matrix that does not allow for access of oxygen. Therefore solely the temperature response of the indicator can be measured and can be used for compensation of the oxygen measurements.

In the meantime optodes (Minisensor PSt3) based on 2 mm POF for the use with the PreSens FIBOX (www.presens.com) became commercially available. The sensitive layer used in these sensors is constructed from a platinum porphyrine indicator immobilised in polystyrene nano-particles that are subsequently immersed in a silicone matrix. This matrix is very adhesive and flexible. The 20-30 μm sensing layer is coated on a 125 μm Mylar film and it may be covered by an optically insulating layer in order to suppress potential outer background fluorescence (e.g. by chlorophyll). This type of sensor membrane is also available from PreSens in 4 cm^2 sheets which may be used to construct custom-made sensors. For special purposes the silicone matrix containing the fluorescent dye nano-particles may also be peeled off the carrier film and attached directly to a fiber using transparent silicone.

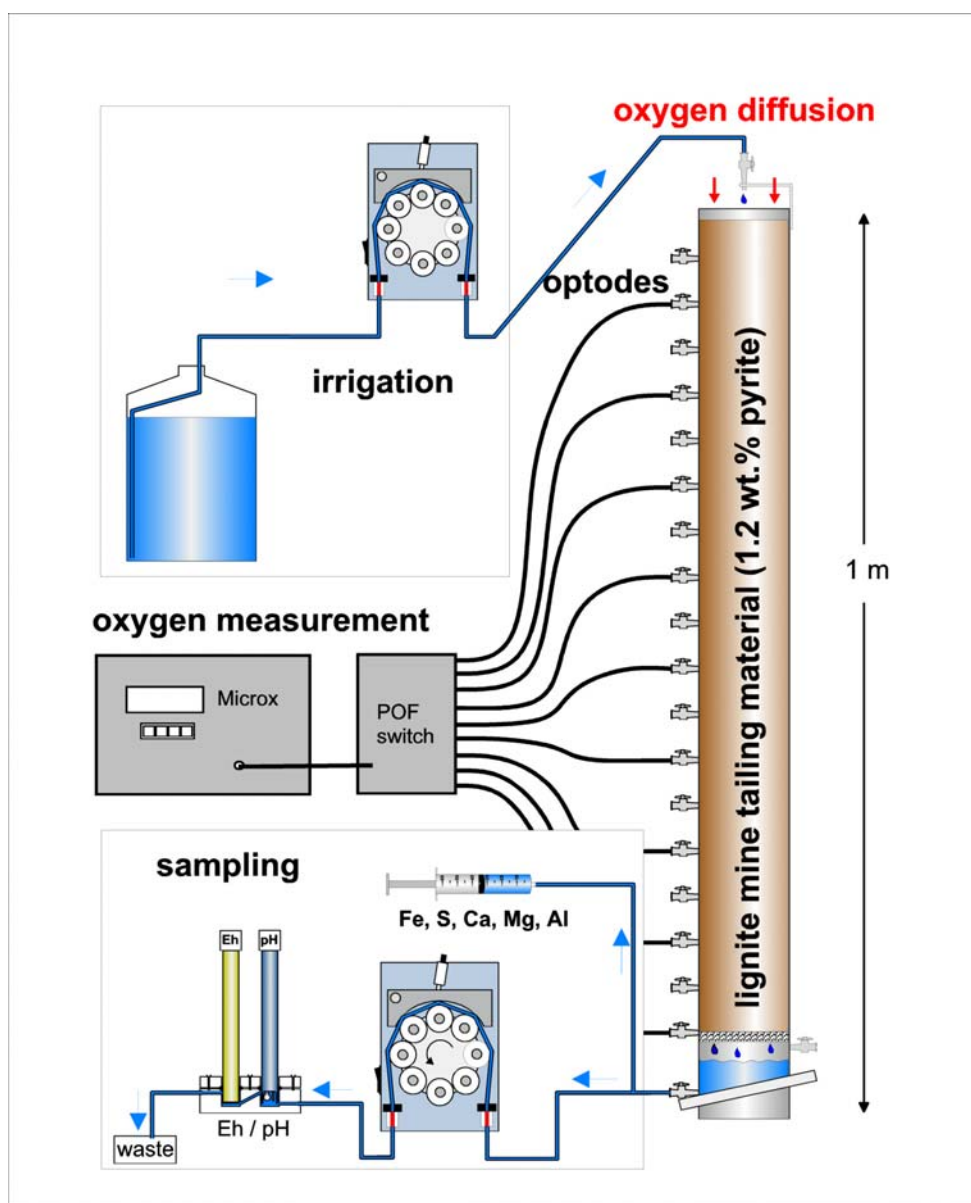

Figure 5: Schematic drawing of column experiment setup (modified after Hecht¹⁶). The Perspex columns (length = 100 cm, I.D.= 10 cm) are filled with material from lignite mine tailings containing 1.2 wt.% pyrite. The columns are open to ambient air at the top. They are irrigated in intervals of 1h. Samples are collected once a week. Type II optodes are installed in 9 depths.

3. EXPERIMENTAL SETUPS AND RESULTS

The type II minioptodes were used in both, laboratory column experiments and in the field. For the permanently installed sensors, reference optodes from the same batch of manufacturing were calibrated and used to correct the measured values for sensor drift, while a calibration of the installed sensors prior to each measurement was impossible. In the laboratory column experiments the measurements can be checked by measurements with calibrated microoptodes.

3.1 Laboratory Column experiments

In long-term column experiments the ground air oxygen concentration in the pore-space of water-unsaturated sediments from lignite mine tailings was monitored using both, microoptodes and minioptodes.

Different experimental setups were chosen. The first columns were equipped with sampling ports that allowed inserting the type I minioptodes or microoptodes in a standard one-way needle casing (commercially available from PreSens). In this setup the optodes may be calibrated prior to each measurement, however, the signal may be disturbed by small amounts of ambient air that may be introduced through the sampling port during insertion of the sensor. For experiments for the determination of the physical properties of the soils, silica fiber microoptodes were permanently installed at different depths and the diffusive recharge of oxygen into a soil column, that initially was oxygen free, was monitored. For these experiments a MICROX 1 equipped with a fiber switch¹³ was used, which allowed automatic switching between eight sensors at an acceptable attenuation introduced by the switch. In further column experiments type II sensors were permanently installed at different depths of the column (figure 5) and oxygen concentrations at all depths were automatically monitored using a simple fiber-switch¹² based on a standard linear stage.

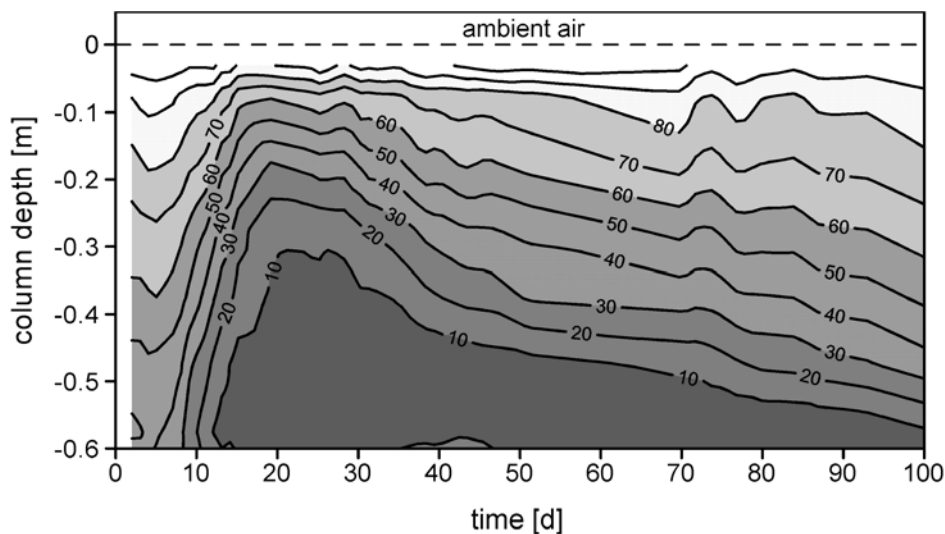

Figure 6: Change in oxygen concentration distribution with time in a column filled with pyrite bearing sediment from a lignite mine tailing (from Hecht&Kölling¹²). The columns are open at the top. The contours show oxygen concentration in % air saturation. Measurements were performed daily during the first three weeks and subsequently every second day.

Using this setup, the change in the oxygen depth distribution (figure 6) could be monitored without disturbance of the diffusion process. In the pyrite bearing column under investigation the oxygen concentrations decrease within the first three weeks resulting in a steep oxygen gradient. This initial phase is followed by a period of constant gradients (4th week) which subsequently decrease with time. This general kind of characteristics is found in all column diffusion experiments with pyrite bearing sediments and may be seen as typical also for field situations where pyrite bearing sediments are aerated.

The change in the oxygen distribution (figure 6) is caused by the oxygen consumption associated with the pyrite weathering process. Since the pore space of the column is initially filled with ambient air, the contained oxygen is consumed first and the microbiological community mediating the pyrite weathering reactions evolves during this initial period. Between 20 and 30 days there is an equilibrium between oxygen consumption in the upper layers and diffusive oxygen recharge. During this period, there is no pyrite weathering in the lower layers of the system since oxygen is completely consumed above. Within the first 8 weeks of the experiment, pyrite weathering occurs throughout the column where oxygen is still available (approximately above the 10% oxygen saturation contour).

As the pyrite in the upper layers becomes dissolved, a narrow pyrite weathering front evolves (approximately delimited by the 10% and 20% contours) which proceeds into greater depths as the sediment layers becomes pyrite-free. Since the diffusion distance increases as the depyritization front proceeds, the depyritization is rapid in the initial phase and subsequently decreases exponentially. As it can be seen from the oxygen distribution measurement, the overall effect is rapid as well - in the example presented, the pyrite in the upper 50 cm of the sediment column with an initial pyrite content of 1.2 wt.% is dissolved within the first three months of the experiment. The release of pyrite weathering products into the seepage water known as acid mine drainage formation in this case results in effluent pH values below pH 2 and very high iron (250 mmolL^{-1}) and sulfate (500 mmolL^{-1}) concentrations.

3.2 Field test

An array of type II minioptodes was constructed from eight oxygen optodes and eight temperature optodes fixed to a plastic tube support such that the sensor tips had a distance of 1m from each other. The sensor array was installed in an 8 m deep borehole on a 40 year old lignite mine tailing (figure 7, figure 8 left). The optodes remained inside the dump body as permanent *in-situ* sensors. Special conditions for this sensor setup are the strongly acidic conditions found inside lignite mine tailings (pH 2 and below) and the fact, that the optodes could be calibrated only prior to installation. The lowermost sensors had a total fiber length of 9 m.



Figure 7: Field situation with a battery-operated MICROX 2 prototype modified for the use with 1 mm POF sensors. 16 optodes (8 oxygen and 8 temperature optodes) were permanently installed in a borehole which was refilled after installation. The instrumental face ends of the fibers are equipped with all metal SMA connectors.

The field measurements were conducted with a battery-operated MICROX 2 prototype modified for the use with POFs. The switching between the sensors at different depths was conducted manually. While it was expected that the pyrite oxidation and the formation of acid mine drainage was completed on this relatively old site, the measurements show an oxygen gradient pointing to very low concentrations at a depth of approximately 6 m (figure 8). This showed, that although this part of the tailing was 40 years old, there was still active pyrite weathering at this depth while the layers above are pyrite-free due to past pyrite oxidation. First reliable results were obtained already 2 hours after refilling the borehole. Eight weeks after installation the sensors showed basically the same results showing the long-term stability of the sensors even under acidic conditions. In combination with model calculations¹⁴ a quick assessment of the state of the acid mine drainage producing system may be performed, allowing a rough prediction of the expected amount of acid release.

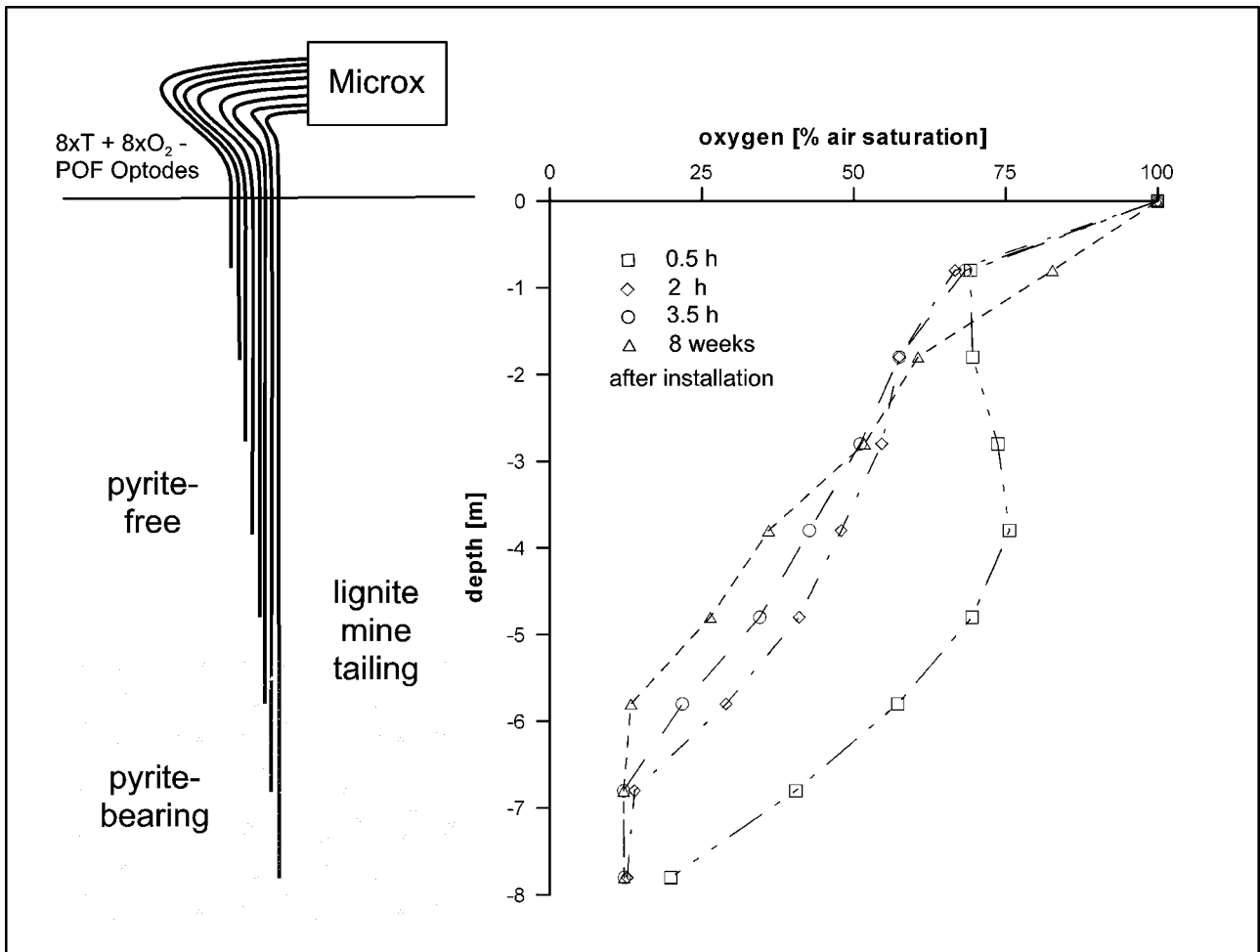

Figure 8: **left:** Schematic drawing of the experimental setup. **right:** Ground air oxygen distribution in a lignite mine tailing. Measurements were performed 0.5 h , 2 h, 3.5 h and 8 weeks after installation. Already 2 hours after installation, values close to the equilibrium situation measured after 8 weeks are obtained. The measurements after 8 weeks are only corrected for sensor drift by an external reference optode calibration (modified after Hecht&Kölling¹²).

4. CONCLUSIONS

Using appropriate coupling techniques, effective measuring systems can be assembled for both microoptode and mini-optode measurements. The signal strength of mini-optodes based on 1 mm or 2 mm POFs allows the use of simple fiber optical switches based on linear stages¹². The luminescence lifetime measurement technique used in the fiber optical oxygen meters presented is well suited even for field applications. The new presented simple mini-optode based on sensor foil spots attached to POFs allows a very flexible custom-made design for different purposes. Especially for all measurements where high spatial resolution and rapid response times are not conditional for the application, these sensors are a rugged and inexpensive alternative to the fragile microoptodes. The long-term stable characteristics of the applied sensor foils show that *in-situ* sensors may be left in the systems of interest to allow long-term monitoring. Apart from the application presented in this paper, the ground air oxygen concentration distribution is critically important for the assessment of organic matter decomposition processes and for controlling the efficiency of oxidative remediation measures on sites affected by organic pollutants. As long as the optode sensor tip is not interfered by the chemicals involved, optode measurements seem to be an attractive alternative to ground air sampling followed by gas analysis.

ACKNOWLEDGEMENTS

This work was supported by the Deutsche Forschungsgemeinschaft (DFG-Ko-1656/2-2). This paper represents publication N° 173 of the Priority Program 546 "Geochemical processes with long-term effects in anthropogenically affected seepage water and groundwater". Thanks to Achim Stangelmayer (PreSens Precision Sensing GmbH, Regensburg, Germany), Ingo Klimant (Technical University of Graz, Austria) and Holger Horstmann.

REFERENCES

1. R.N. Glud, I. Klimant, G. Holst, O. Kohls, V. Meyer, M. Kühl and J.K. Gundersen, „Adaptation, Test and in situ Measurements with O₂ Micropt(rod)es on Benthic Landers“, Deep Sea Research 46, pp.171-183, 1999..
2. G. Holst, M. Kühl and I. Klimant, „A Novel Measuring System for Oxygen Microoptodes Based on a Phase Modulation Technique“, SPIE Chemical, Biochemical and Environmental Fiber Sensors VII, 2508, pp. 387-398, 1995.
3. G. Holst, R.N. Glud, M. Kühl and I. Klimant, „A Microoptode Array for Fine Scale Measurement of Oxygen Distribution“, Sensors and Actuators B, 38, pp. 122-129, 1997.
4. G. Holst, M. Kühl, I. Klimant, G. Liebsch und O. Kohls, „Characterization and Application of Temperature Microoptodes for Use in Aquatic Biology“, SPIE Advances in Fluorescence Sensing Technology III, 2980, pp. 164-170, 1997.
5. I. Klimant, V. Meyer and M. Kühl, „Fiber-Optic Oxygen Microsensors, a New Tool in Aquatic Biology“, Limnology and Oceanography, 40 (6), pp. 1159-1165, 1995.
6. I. Klimant, G. Holst and M. Kühl, „Oxygen microoptodes and their application in aquatic environment“, SPIE Chemical, Biochemical and Environmental Fiber Sensors VII, 2508, pp. 375-386, 1995.
7. I. Klimant, M. Kühl, R.N. Glud und G. Holst, „Optical Measurement of Oxygen and Temperature in Microscale: Strategies and Biological Applications“, Sensors and Actuators B, 38, pp. 29-37, 1997.
8. I. Klimant, G. Holst and M. Kühl, „A Simple Fiber-Optic Sensor to Detect the Penetration of Microsensors into Sediments and Other Biological Materials“, Limnology and Oceanography, 42 (7), 1997.
9. O. Kohls, I. Klimant, G. Holst und M. Kühl, „Development and Comparison of pH Microoptodes for Use in Marine Systems“, SPIE, 2978, pp. 82-91, 1997.
10. Z. Rosenzweig and R. Kopelman, „Development of a Submicrometer Optical Fiber Oxygen Sensor“, Analytical Chemistry, 67, pp. 2650-2654, 1995.
11. W. Tan, Z.-Y. Shi, S. Smith, D. Birnbaum and R. Kopelman, „Submicrometer Intracellular Chemical Optical Fiber Sensors“, Science, 258, pp. 778-781, 1992.
12. H.Hecht and M. Kölling, "A low-cost optode-array measuring system based on 1mm plastic optical fibers - new technique for in-situ detection and quantification of pyrite weathering processes", 7 p., Sensors and Actuators B, in press.
13. H.Hecht and M. Kölling " A very low attenuation fiber-optical sensor switch (LAFOSS)", 4 p., Sensors and Actuators B, in press.

14. H. Hecht, M. Kölling and N. Geissler, "DiffMod7 - modeling oxygen diffusion and pyrite decomposition in the unsaturated zone based on ground air oxygen distribution" , in: "Geochemical Processes - Concepts for Modeling Reactive Transport in Soils and Groundwater", Wiley-VCH, Weinheim, in press.
15. G. Holst, I. Klimant, M. Kühl and O. Kohls, "Optical Microsensors and Microprobes", in "Chemical Sensors in Oceanography", ed.: M. Varney, OPA Overseas Publisher Association, Amsterdam, pp. 143-188, 2000.
16. H. Hecht "Optodenmessung zur Bestimmung diffusiver Sauerstoffnachlieferung bei der Pyritverwitterung", 90 p. Diploma thesis Univ. of Bremen, Dept. of Geosciences, Bremen, Germany, unpublished.